

SIMPLIFIED MEXICAN COLOR TV

By LESLIE SOLOMON
Associate Editor

Developed in Mexico, this simple approach to TV switches a three-gun CRT at field rate.

FOR the past year, a TV station, XHGC-TV in Mexico City, has been transmitting an experimental color program every Saturday morning. Although this is not unusual, considering the present state of the art in the U.S.A., what is different is that this station is transmitting a compatible color signal using a simple switching technique developed in Mexico.

The new color system, called Simplified Bicolor System (SBS) and shown in block diagram form in Fig. 1, uses a conventional monochrome transmitter with a special camera and associated switching system. The camera is so arranged that during one field interval, the camera output consists of the red-orange components of the scene being televised and, during the other field interval, camera output is the blue-green component. Because monochrome pulse standards are used, the system is compatible.

The receiver is a conventional monochrome unit feeding a three-gun color CRT. There are no chromatic circuits such as required for viewing the NTSC color signal. Instead, the vertical sync signal is used to switch the red and blue-green guns of the color CRT in accordance with the transmitter. Once the field switching is synchronized, there are no other color controls (except preset individual gun brightness) and color saturation is handled by the contrast control.

Transmitter

The transmitter is a conventional monochrome unit, operated with standard monochrome pulses, but with a special color camera and its associated field-level corrector.

At present, the experimental camera consists of a dual-filter color wheel rotating at field rate in front of an image orthicon with one half of the transparent filter passing only red-orange (700 to 580 millimicrons) and the other half passing blue-green (580 to 470 millimicrons).

Another variation of the camera is being considered. Here, a pair of image

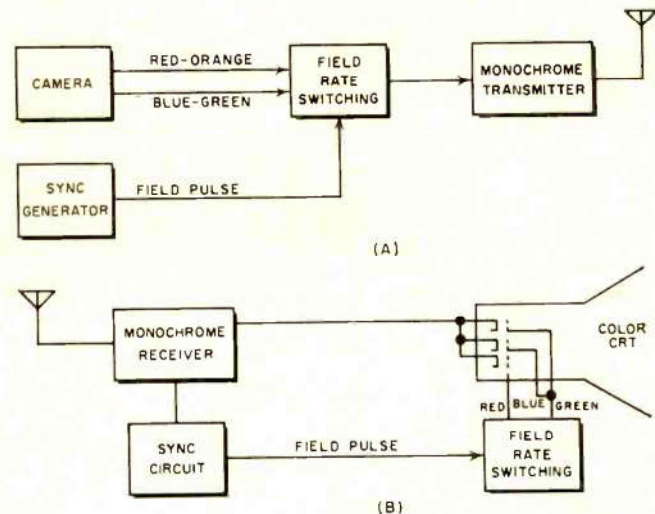

Fig. 1. (A) Transmitter switches between blue-green and red-orange signals at field rate. (B) Receiver is synchronized with transmitter by vertical sync pulse to produce images.

orthicons, each with its own filter, is used with the outputs switched into the transmitter at field rate.

Although standard monochrome pulses are used in this color system, it is necessary that each vertical picture field be compensated to avoid the "blinking" that would be annoying if one color field had areas of greater brightness than the other. The "blinking" that is caused by differences in color brightness between fields is reduced by using a maximum color saturation of 60% for each individual color field.

The "blinking" that would be produced by unequal average levels in each field is reduced by a compensating circuit. In this circuit, the uncompensated video is applied through a vacuum-tube mixer whose other input is a square wave having a duration of one field. The field level control adjusts the level of the square wave fed to the mixer so that each field output is biased to average the brightness levels. Once this control is set, there are no other chromatic controls required at the transmitter.

Receiver

The receiver for use with this color system can be either a conventional black-and-white receiver equipped with a color CRT with its associated color purity components and circuits, but not with any of the usually used chromatic circuits, or a color-TV set with its associated color tube and color purity components and circuits, with the chromatic circuits disabled.

In place of the normally used color signal extraction and processing circuits found in NTSC signal receivers, the electronics for this system consists of an electronic switch operating at field rate (30 cps) synchronized by the vertical sync pulse. The circuit is shown in Fig. 2.

The vertical pulse is amplified by V1 and is used to synchronize 30-cps multivibrator V2-V3. The 30-cps output signal from this multivibrator is amplified by V4 and V5 with the resultant signal used to gate the color CRT on and off (Continued on page 71)

Fig. 2. This is the color switching circuit for the Mexican color system. The color CRT guns are gated in the correct order by a 30-cps triggered multivibrator.

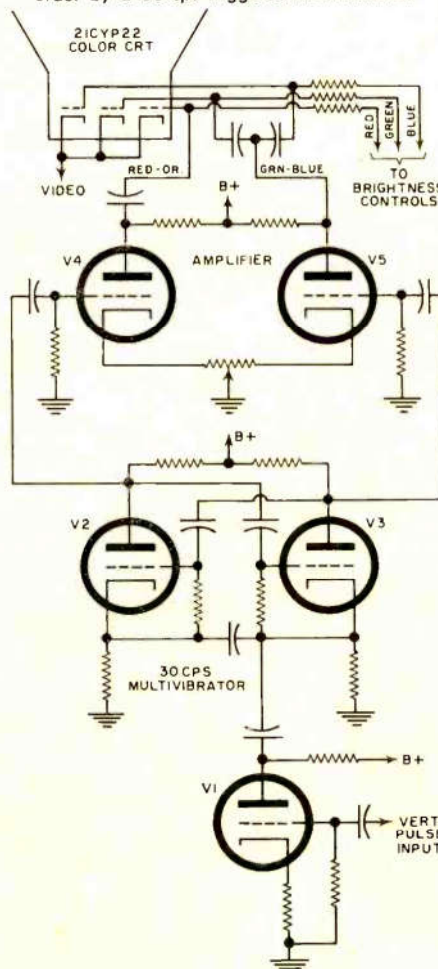

Mexican Color TV

(Continued from page 48)

at the 30-cps rate. When using a conventional color CRT, one amplifier operates the red gun while the other amplifier gates both the blue and green guns connected in parallel. The red gun is operated during the odd number fields while the green and blue guns operate during even number fields.

Once the field switcher is operating and individual electron gun brightness is determined, and the video applied to the three cathodes connected in parallel, color saturation is determined by operation of the set's contrast control.

An experimental circuit has been designed and built that is capable of distinguishing between odd and even fields. The output from this circuit is used to lock the CRT electronic field switch.

Color CRT

To display this two-color system properly, three-gun tubes such as the 21CYP22 whose persistence is approximately 28 milliseconds for the red and 25 milliseconds for the green is used. Such long persistence means that "blinking" of the viewed picture will be reduced. A CRT with a shorter persistence such as the 21FJP22 whose red and

green phosphor persistence is approximately 60 microseconds (about 1 horizontal line time) will produce "blinking" of the received picture.

Because the red-orange scan falls on odd number fields and the blue-green scan falls on even number fields, it becomes possible to design a two-color CRT with a screen consisting of red-orange and green-blue stripes alternating from top to bottom of the CRT. Such a tube is under design at the moment and, when operational, is expected to greatly reduce the cost of receivers capable of receiving this latest approach to the transmission of color TV.

This Mexican-developed color-TV system joins the NTSC (American-developed compatible system in use today), PAL (phase-alternate line method of color transmission and reception developed in Germany), and the SECAM (a third color system developed in France). Each of these systems has its good points and each has certain drawbacks.

Although this Mexican system suffers from certain color deficiencies, it appears to use what are probably the simplest circuits of the four systems.

Our thanks to Ing. Jesus Carvajal Sosa who provided details of this system invented by Dr. Guillermo Gonzales Camarena, chief technical advisor for *Telesistema Mexicano*, Mexico City. ▲

RACKS FOR TEST EQUIPMENT

By JAMES L. HARTLEY

FOR the protection of v.t.v.m.'s, signal generators, and other test instruments, we have found it desirable to mount them in plywood racks as shown in the photograph below.

Such racks protect the instruments from damage; keeps them from falling over on the bench, and provides ready storage for tests leads and line cords. The dry cell for the v.t.v.m. is mounted outside the case for easier access. Also, the instrument is easier to read in the sloping-front position.

The two side panels of the rack are of 3/8" plywood with an 8" base and a height of about 11". The baseboard is

1/2" plywood, 8" wide with a length to accommodate the width of the instruments. A strip of Masonite across the back makes a good place to tuck in the line cord. The U-shaped wire is set in at the front edge to hold the test cables.

We found it better to bolt the instrument case directly to the side panels, as seen at the left in the photo below, instead of using the right-angle metal brackets, shown at right.

For school use, we have a large number of instruments mounted in such racks and any technician with a few pieces of test equipment could easily adapt this same idea to his own needs. ▲

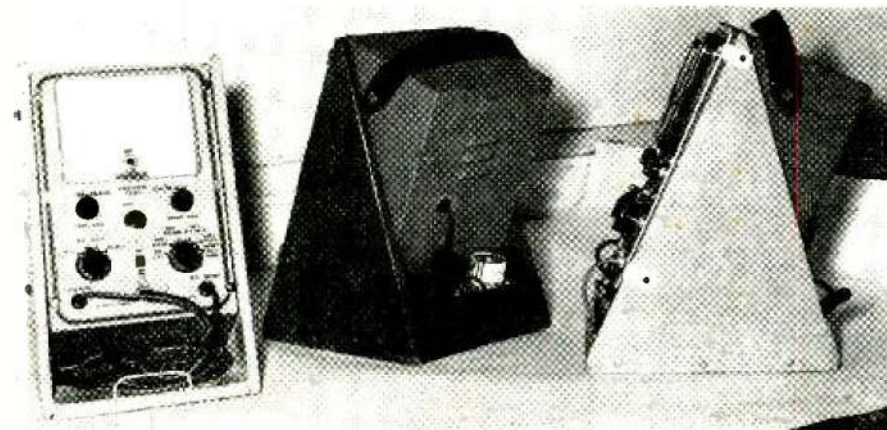

July, 1964

NOW—YOU CAN PLAY A VITAL ROLE IN SPACE AGE COMMUNICATIONS

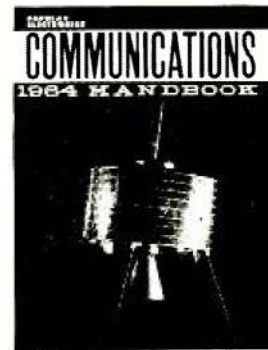

THE 1964 COMMUNICATIONS HANDBOOK

is the only publication that covers the entire specialized field of today's rapidly expanding radio communications. It gives you 148 fact-filled pages—complete with charts, graphs and tables—covering:

- *Citizens Band*
- *Short-Wave Listening*
- *Ham Radio*
- *Business Radio Services*

PLUS THESE SPECIAL FEATURES:

Up-to-the-minute Space Data
Latest US and Canada License Requirements
A Build-it-yourself World Time Calculator

Look for the 1964 COMMUNICATIONS HANDBOOK—it's *now on sale* at your newsstands or electronics parts store. Or, if you prefer, use this handy coupon for ordering your copy of the 1964 COMMUNICATIONS HANDBOOK.

Ziff-Davis Service Division, Dept. CH EW74
589 Broadway, New York 12, New York

Please send me _____ copies of COMMUNICATIONS HANDBOOK, at \$1.00 each—plus 15¢ mailing and handling charge on each. (Canada and Overseas: \$1.25 plus 25¢ postage.)

I enclose _____

NAME _____

ADDRESS _____

CITY _____ ZONE _____ STATE _____